

A Workbook Designed for use with the
EP Henry Idea Catalog

Do-It-Yourself!



INSIST ON THE BEST.



DIY

Do-It-Yourself
with **EPHENRY** Garden Walls

Wall Color Selections

Standard



RED



GRAY



TAN



PEWTER BLEND



HARVEST BLEND



AUTUMN BLEND



BUFF

Coventry® Wall



PEWTER BLEND



HARVEST BLEND



AUTUMN BLEND



DAKOTA BLEND



BUFF

Not all Wall Systems are available in all colors; for stock color selections, please refer to the EP Henry Idea Catalog or go to www.ephenny.com.



Pewter Blend Terrace Wall™



Dakota Blend Double Sided Coventry® Wall



Tan English Garden Wall™

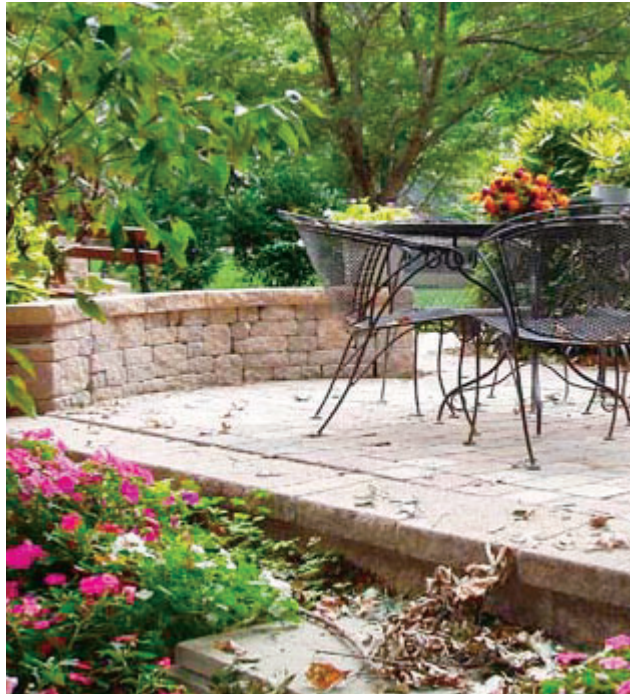

Harvest Blend Coventry® Wall

DIY

Do-It-Yourself
with **EPHENRY**

A Workbook Designed for use with the
EP Henry Idea Catalog

Garden Paths & Patios



Red Brick Stone

Not all Pavers are available in all colors; for stock color selections, please refer to the EP Henry Idea Catalog or go to www.ephenny.com.



Harvest Blend Octa Grande®



Harvest Blend Coventry® Stone I

Paver Color Selections

Standard



RED



NATURAL



CHARCOAL



BROWN



TAN



AUTUMN BLEND



HARVEST BLEND



PEWTER BLEND



FALL BLEND



DAKOTA BLEND



AZALEA*

*Premium Colors

Coventry® Pavers



HARVEST BLEND



PEWTER BLEND



DAKOTA BLEND



AUTUMN BLEND



BUFF

CONTENTS



	PAGE
IDEA PHOTO GALLERY	2
CONTENTS	4
PLANNING YOUR EP HENRY PAVER PROJECT	5
CALCULATING PAVER REQUIREMENTS	6
PAVER COST WORKSHEET & TOOL CHECKLIST	11
COVENTRY® CURBSTONE & EDGESTONE	12
GRID PAPER FOR PROJECT FIGURING	15
PLANNING YOUR EP HENRY WALL PROJECT	17
WALL GUIDES	
NURSERY STONE®, ENGLISH GARDEN WALL™	
& COVENTRY® GARDEN WALL	18
TERRACE WALL™	19
STONEWALL® SELECT™, MESA®, VERTICA®	
& DIAMOND PRO™	21
COVENTRY® WALL	23
DOUBLE SIDED COVENTRY® WALL	25
WALL COST WORKSHEET & TOOL CHECKLIST	27
DO-IT-YOURSELF CONTEST FORM	28
DO-IT-YOURSELF PHOTO GALLERY	29



INSIST ON THE BEST



A Do-It-Yourself's Guide to Planning an EP Henry Paver Installation

Before you start an EP Henry Paving Stone installation yourself, consider the following questions:

- Have you watched an installation video or read installation instructions thoroughly?
- Are you in good physical condition and able to lift the weight of the units you plan to use?
- Do you feel confident enough to lift and operate power equipment?
- Do you know how to use a tape measure and level and perhaps even a transit?
- Do you have a place to put the excavated soils?
- Are you building on clay soils?
- Will the pavement need to support vehicles?

Consider these points before proceeding. If you feel the job may be too much for you to handle on your own, you may want to consider hiring an EP Henry Authorized Hardscaping Contractor.

Estimating guidelines are intended to be used in conjunction with the EP Henry Idea Catalog.

Product Selection Table

Product	Application		
	Patio	Walkway	Light Vehicular Driveway
Octa Grande®	X	X	X
Brick Stone	X	X	X
Old Towne Cobble	X	X	X
Colonial Stone®	X	X	X
Symetry®	X	X	X
Village Square®	X	X	N/A
Coventry® I, II, III & IV	X	X	X

General Installation Guidelines

Before you begin, call your local utilities company to check your yard for buried electrical lines, cables, etc. This step is essential for your safety, is required by law and is free in most areas. Also, check with your municipality to see if you'll need a construction permit. "Call Before You Dig" toll free numbers are listed below by state:

Delaware	800-282-8555	New York	800-962-7962
District of Columbia	800-257-7777	Pennsylvania	800-242-1776
Maryland	800-282-8555	Virginia	800-552-7001
New Jersey	800-272-1000		

Please visit your EP Henry Authorized Hardscaping Center or visit our web site (www.ephenry.com) for installation instructions and guidelines. HomeTime has a great "how-to" video or cd on paver installation which is available through your EP Henry Hardscaping Center. They also have installation directions on their website: <http://www.hometime.com/Howto/projects/patios.htm>. For additional information you may also contact the Interlocking Concrete Pavement Institute (www.icpi.org).

PAVER Installation

- 1 Determine your project type. This will determine the appropriate depth of the base material, necessary for a good and long-lasting installation.
 - Patio/Walkway (minimum 6" of modified stone base material)
 - Residential Driveway (minimum 10" of modified stone base material)
- 2 Make a sketch of your project. Be sure to include dimensions of your pavement and any other distances or dimensions that might affect the final installation.
- 3 Calculate the square footage of the area that you wish to pave. Some guides to help you:

The basic formula for calculating area is Length times Width (L x W). If you are estimating the area for a rectangle you'll always use L x W.

When calculating the area for a pavement with multiple sections, like an L-shape, divide the pavement into two sections, then calculate the area for each section and add them together.

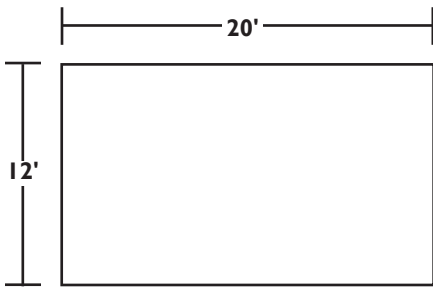

Figure 1

The illustration above shows a pavement 12' wide by 20' long. Area calculated as:

$$L \times W = 20 \times 12 = 240 \text{ SF}$$

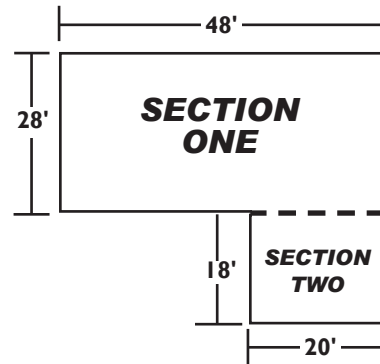

Figure 2

For example, in the L-shaped pavement above the two sections have been divided to calculate the total area. Section one is 28 x 48. Section two is 20 x 16. The area calculation is:

SECTION ONE	28 x 48 =	1,344 SF
SECTION TWO	20 x 16 =	320 SF
TOTAL		= 1,664 SF

The total square feet of pavement needed for my project is: _____ x _____ = _____ sf

Example (from Figure 1 above): 12' x 20' = 240 sf

- 4 Take the total square footage figure from #3 above and multiply times 1.03. This will add 3% for waste, cuts, etc. The total square feet of pavers needed (including waste) for my project is: _____ x 1.03 = _____ sf (from #3)

Example (from Figure 1 above): 240 x 1.03 = 247 sf

- 5 Ok, here's where it gets just a bit tricky. If your project will not have a border, or if the border is made up of the same color and shape paver as the field (the main area of pavers), go to step 6. If the pavement will have a border, you'll have to calculate the quantity of pavers required for the border and then subtract this from the total square footage to see how much you'll need for the field.

Add up the lengths of all the sides of the pavement where your border will be. Typically, either a Brick Stone or 6x9 Paver (Old Towne Cobble™ or Coventry® I) is used as the border paver.

PAVER Installation

To calculate how many square feet of pavers you'll need for the border, divide the total linear footage (the lengths of all the sides of the pavement where you'll have the border) by the number in the chart next to the border paver that you plan to use. These numbers assume a soldier course as shown at right:

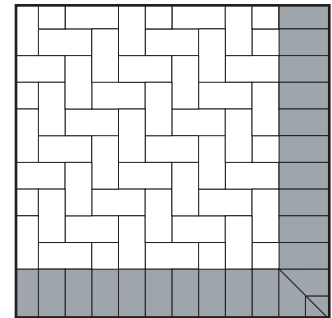

Soldier course border

Border Paver	Divide total lineal footage by
Brick Stone	1.50
6x9 Old Towne Cobble™ or Coventry® I	1.33

For example, we'll assume that all four sides of the patio shown in Figure 1 will have a 6x9 Old Towne Cobble Border.

a. The total lineal feet of my paver border is:

$$\underline{\hspace{2cm}} + \underline{\hspace{2cm}} + \underline{\hspace{2cm}} + \underline{\hspace{2cm}} = \underline{\hspace{2cm}} \text{ lineal feet}$$

Example: 12' + 20' + 12' + 20' = 64 lineal feet

b. Therefore, the total square feet of border pavers is:

$$\frac{\underline{\hspace{2cm}}}{\text{(from 5a)}} \div \frac{\underline{\hspace{2cm}}}{\text{(from chart)}} \times 1.03 = \underline{\hspace{2cm}} \text{ sf}$$

Example (assumes a 6x9 Old Towne Cobble border): 64 ÷ 1.33 x 1.03 = 50 sf

c. Finally, calculate the total square feet of pavers for the field by subtracting the total square feet needed for the border from the total square feet required for the entire project.

$$\frac{\underline{\hspace{2cm}}}{\text{(from 4)}} - \frac{\underline{\hspace{2cm}}}{\text{(from 5b)}} = \underline{\hspace{2cm}} \text{ sf}$$

Example: 247 - 50 = 197 sf

6 Select the paver shape and pattern for your project. Some patterns require more than one paver shape. The paver shape and patterns listed on the following page are the most basic and represent only a portion of all the possible shape and pattern combinations.

PAVER Installation

Paver	Pattern	Paver 1	%	Paver 2	%
Brick Stone or or Coventry® Brick Stone	Running Bond	BS or Cov BS	100%	-	-
	90° Herringbone	BS or Cov BS	100%	-	-
	Basketweave	BS or Cov BS	100%	-	-
Old Towne Cobble or Coventry Stone	"I" Pattern	6 x 9	70%	6 x 6	30%
	Random	6 x 9	60%	6 x 6	40%
	Running Bond	6 x 9	100%	-	-
Octa Grande *	Runner	Octa Grande	100%	-	-
6x6, 8x8 or 12x12 Village Square	Running Bond	Village Square	100%	-	-
Symetry	Diamond Run	Symetry	100%	-	-
	Venetian Parquet	Symetry	83%	6x6 Village Square	17%
Colonial Stone	Random	Colonial #1 pallet	60%	Colonial #2 pallet	40%

* Octa Grande Pavers also have an Edger. Edgers are ordered separately and deducted from overall square footage of the project. To calculate the square feet of Edgers needed, take the total lineal feet and divide by 3.25.

Multiply the total square footage by the percentage for each paver shape to determine how many of each shape you need for the field (the main area of pavers without the border).

Paver 1 _____ × _____ = _____ sf
(from 5c) (from chart)

Paver 2 _____ × _____ = _____ sf
(from 5c) (from chart)

Example Old Towne Cobble "I" Pattern:

6x9 Old Towne Cobble 197 SF x 70% = 138 sf

6x6 Old Towne Cobble 197 SF x 30% = 59 sf

NOTE: Pavers may be sold by the square foot, piece, band or pallet, depending upon the distributor and packaging.

- 7 This step is important to figure out the amount of fabric, stone base material and bedding sand needed. The base must exceed the finished dimensions of your pavement by at least 6" on all sides that are not up against a permanent structure. This is needed to provide a sturdy base and to support the edge restraint.

Calculate the square footage for the base and all components.

_____ × _____ = _____ square feet

Example (assuming the top side of this patio is up against the house): 21' x 12.5' = 262.5 square feet

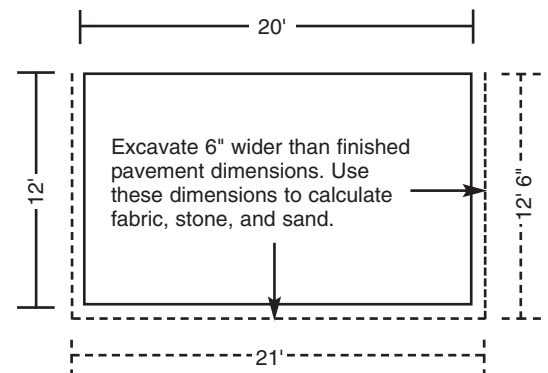

- 8 Determine the quantity of base material needed. Like any construction project, the foundation is the most important part of the installation. Your base should be constructed of ¾" modified stone (also called 2A or crusher run) and compacted 2 inches at a time. Multiply the number from the table below times the total square footage figure from Step #6 to determine how many tons of stone you'll need.

Base Depth Multiplier	
6"	.03
8"	.04
10"	.05
12"	.06

$$\frac{\text{_____}}{\text{(from \#6)}} \times \frac{\text{_____}}{\text{(from chart)}} = \text{_____ tons of base}$$

Example (we'll assume this is a patio with a 6" base depth):
262.5 sf x .03 = 7.87 tons

- 9 Calculate the square footage of base separation fabric needed. Base separation fabric prevents the modified stone base from working its way into the subgrade and, thus, maintains the integrity of your base. While it is recommended for all installations, fabric is a must if your soils have a lot of clay. Take the total square footage figure from Step #7 and multiply by 1.1. This will give you enough fabric to go under your entire installation and to flash up the side walls of the excavated area.

$$\text{_____} \times 1.1 = \text{_____ sf of separation fabric}$$

Example: 262.5 SF x 1.1 = 289 sf

- 10 Determine the quantity of bedding sand needed. The bedding sand "seats" the pavers and is a main component of the interlock. The bedding material should be coarse concrete sand. Do not use stone dust or screenings. Multiply the total square footage figure from Step #6 by .005 to determine how many tons of sand you'll need.

$$\frac{\text{_____}}{\text{(from \#6)}} \times .005 = \text{_____ tons of bedding sand}$$

Example: 262.5 sf x .005 = 1.31 tons

PAVER Installation

11 Determine the quantity of joint sand needed. EP Henry Polysand is a pre-bagged, dry polymeric sand that will set up in the paver joints when moistened. It will inhibit weeds and pests and resist erosion. Divide your total square feet by the appropriate number in the column below (depending upon paver) to determine how many bags of sand you'll need. Round up to the nearest whole number, as you have to buy full bags.

Paver Type	Coverage
Standard	Approx. 75 square feet
Tumbled (Coventry)	Approx. 45 square feet

$$\frac{\text{_____}}{\text{(from \#6)}} \div \frac{\text{_____}}{\text{(from chart)}} = \text{_____} \text{ bags of EP Henry Polysand}$$

Example (using Old Towne Cobble standard finish):

$$262.5 \text{ sf} \div 75 = 4 \text{ (3.5) bags}$$

12 Calculate how much edge restraint you'll need by measuring the perimeter. Edge restraint is absolutely necessary on all sides not supported by a permanent structure (such as a house, wall, etc.). Perimeter is the linear measurement around a shape.

a. The total lineal feet of edge restraint needed is:

$$\text{_____} + \text{_____} + \text{_____} + \text{_____} = \text{_____} \text{ lineal feet of edge restraint}$$

Example (assuming patio is up against house, only three sides need restraining)

$$20' + 12' + 12' + 0 = 44 \text{ lineal feet}$$

b. PaveEdge is sold in 7.5' lengths and SnapEdge in 8' lengths. Take the total lineal feet from 12a and divide by either 7.5 (PaveEdge) or 8 (SnapEdge) to calculate how many pieces you'll need. Round up to the nearest whole number, as you have to buy full pieces.

$$\frac{\text{_____}}{\text{(from \#12a)}} \div \frac{\text{_____}}{\text{(from chart)}} = \text{_____} \text{ pieces of edging}$$

Edge Restraint Length	
Pave Edge	7.5'
Snap Edge	8.0'

Example (assumes SnapEdge is being used):

$$44 \div 8 = 6 \text{ (5.5) pieces}$$

13 You'll need spikes to hold the edge restraint in place. Use one for every 1.5' of edge restraint.

$$\frac{\text{_____}}{\text{(from \#12a)}} \div 1.5 = \text{_____} \text{ spikes}$$

Example: $44 \div 1.5 = 30 \text{ (29.33) spikes}$

Step#	Product	Calculation	Unit	Price	Extended
4	Total square feet of pavers needed		SF		
5b	Total square feet of paver border (if different from field)		SF		
	Paver border shape/color				
6	Total square feet of pavers needed for field (if different from border)		SF		
	Field Paver 1 shape/color				
	Total square feet of pavers needed for field (if different from border)		SF		
	Field Paver 2 shape/color				
8	Base material		Tons		
9	Square feet of base separation fabric		SF		
10	Bedding sand		Tons		
11	EP Henry Polysand (joint sand stabilizer)		Bags		
12b	Edge Restraint		Pieces		
	Edge Restraint type				
13	Spikes		Spikes		
	Total Material Cost				
	Tool rental				
	Delivery				
	Miscellaneous *				
	Tax				
	Project Total				

*For more Paver Accessories, such as Techni-Seal Cleaners & Sealers and Lighting options, please refer to the EP Henry Idea Catalog or go to our website: www.ephenry.com.

Don't forget our special financing through Commerce Bank to help pay for your project!

Tool Checklist for Patios and Walkways

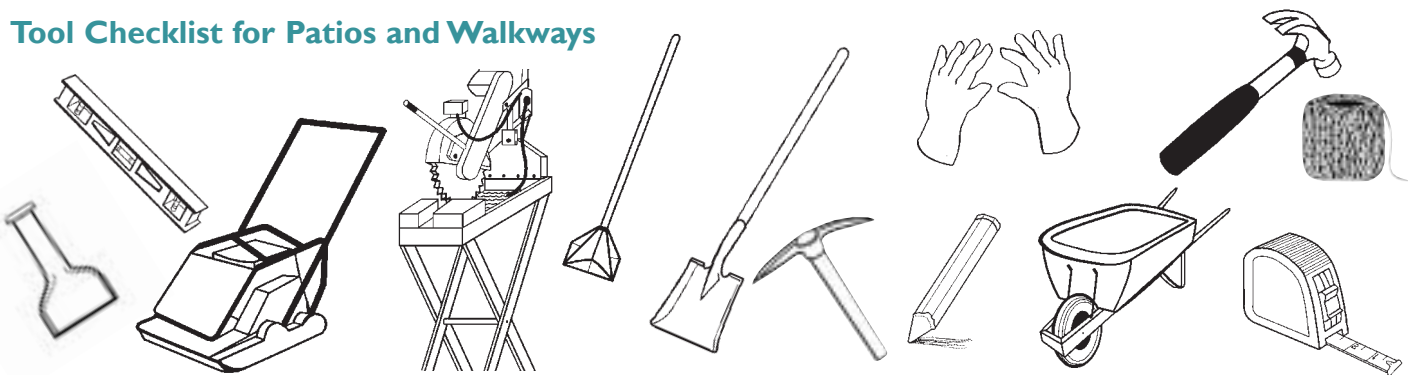

- Shovel
- Steel rake
- Push broom
- Hand tamper
- Wheelbarrow
- Garden hose
- Tape measure
- Level
- Stringline
- Chalkline
- Trowel
- Screed rails
- Screed board
- Marking utensil
- Gloves
- Dust mask
- Eye protection
- Ear protection
- Vibratory plate compactor
- Table saw with diamond tip blade

COVENTRY® CURBSTONE & EDGESTONE

Material Calculations



Coventry
Curbstone



Coventry
Edgestone

- To determine the quantity of Curbstone or Edgestone required, measure the total lineal feet of your project. If the project is curved or serpentine you can layout a garden hose in the shape of the area then stretch out the garden hose and measure the length. The following calculations are based on a 40 foot long edging area.

Coventry Curbstone: Calculate the length in inches and divide by 8.

$$\text{Example: } \frac{480 \text{ "}}{\text{Lineal inches}} \div \frac{8 \text{ "}}{\text{Width of unit}} = \frac{60 \text{ units}}{\text{Total units needed}}$$

Coventry Edgestone: Calculate the length in inches and divide by 6.

$$\text{Example: } \frac{480 \text{ "}}{\text{Lineal inches}} \div \frac{6 \text{ "}}{\text{Width of unit}} = \frac{80 \text{ units}}{\text{Total units needed}}$$

Coventry Curbstone & Edgestone may be laid in either a **sand setting bed** or in a **concrete wet bed**, where additional rigidity is needed (such as driveway borders). For the latter, you would usually also mortar the units together. Depending upon your application, choose either Step 2 or Step 3.

- For sand setting bed to calculate the sand required, take the total linear feet and divide by 6.

$$\text{Example: } \frac{40'}{\text{Lineal feet}} \div \frac{6}{\text{Lineal feet per bag}} = \frac{7 \text{ bags of concrete sand}}{\text{Number of bags needed}}$$

- For the concrete wet bed, you'll need to calculate both the concrete needed for the base and wash *and* the amount of Portland Cement and lime or Easy Spred-Color required to mortar the joints.

(A) To calculate the amount of concrete needed for the base and wash on the backside of the Coventry Curbstone, take the total lineal feet and divide by 3.5.

$$\text{Example: } \frac{40'}{\text{Lineal feet}} \div \frac{3.5}{\text{Lineal feet per bag}} = \frac{12 \text{ bags of concrete mix}}{\text{Number of bags needed}}$$

(B) To calculate the amount of Portland Cement and lime or Easy Spred-Color required to mortar the joints, take the total amount of lineal feet and divide by 100.

$$\text{Example: } \frac{40'}{\text{Total lineal feet}} \div \frac{100'}{\text{Lineal feet per bag}} = \frac{1 \text{ bag each of Portland cement \& lime or Easy Spred-Color}}{\text{Number of bags needed}}$$

ADDITIONAL NOTES:

- You will also need 8 five-gallon buckets of yellow bar sand for each bag of Portland Cement for your mortar.
- EP Henry carries a complete line of Easy Spred-Color, which can be used in place of lime, to complement the color of your Curbstone or Edgestone.
- Consult your EP Henry Hardscaping Center for additional information and tips.

COVENTRY® CURBSTONE & EDGESTONE

Installation

1 JOB LAYOUT Using a string line for straight borders and a garden hose for serpentine walls, mark the ground where the Coventry Curbstone or Edgestone is to be placed with marking paint or lime.



Outline area with marking paint

2 PREPARE FOOTING Dig a trench the width of a shovel and 4" deep. Fill trench halfway with base material. For driveway borders use concrete mix for the base; for garden borders, use sand or screenings for the base.



Concrete footing



Sand footing

3 SETTING THE CURBSTONE OR EDGESTONE Place units in base material so that the two split sides are facing forward (1) and top (2). For wet bed applications, leave 1/2" spacing between the units for mortar joints; for non-mortared applications, place block tightly together. For sand bed applications (which are all non-mortared) fit block closely together and seat the units gently, using a 2"x4" board and hammer, adjusting heights for consistency, as desired.



Sand setting bed application



Wet bed application with mortar joint spacing

Typically, Coventry Edgestone is only used in non-mortared applications.

COVENTRY® CURBSTONE & EDGESTONE

Installation

4 ALIGNING THE BLOCK For serpentine walls, align the back of the block to create a smooth curve to the design. For straight walls, use a string line across the back of the block to verify that you have a straight line.



Serpentine border



String line for aligning the block

5 BACKFILL

For wetbed applications, after seating the Curbstone or Edgestone in concrete, backfill behind it with concrete for additional support. Build a concrete restraint (also known as a cove or a wash) halfway up the block and sloped away

from the unit. Use a trowel to create a smooth angled finish which will strengthen the curbing and reduce water penetration to the concrete footing. For garden border applications, backfill behind the units with soil and compact, then add soil to the front of the units to bring up to finished grade.



Concrete restraint

6 MORTARING THE JOINTS Mix mortar thoroughly and apply using a trowel or mortar bag. Use care not to get mortar on the split face finish. Use a striker to tool the joints.



Mortaring joints with mortar bag



Tooling the joints

HELPFUL TIPS

- One 80 lb. bag of ready mix concrete will cover 3.5 lf of both base and restraint (cove or wash) for wet bed applications of Coventry Curbstone or Edgestone.
- One 94 lb. bag of Portland Cement plus one 50lb bag of lime, or the equivalent volume of Easy Spred-Color, and 8 five-gallon buckets of yellow bar sand will yield enough mortar to tool one pallet or 150 pcs. of Coventry Curbstone or Edgestone.
- Ask your EP Henry Hardscaping Center about Easy Spred-Color for mortar to complement the color of your Coventry Curbstone or Edgestone.

WORK SHEET

Grid Paper for Project Layout

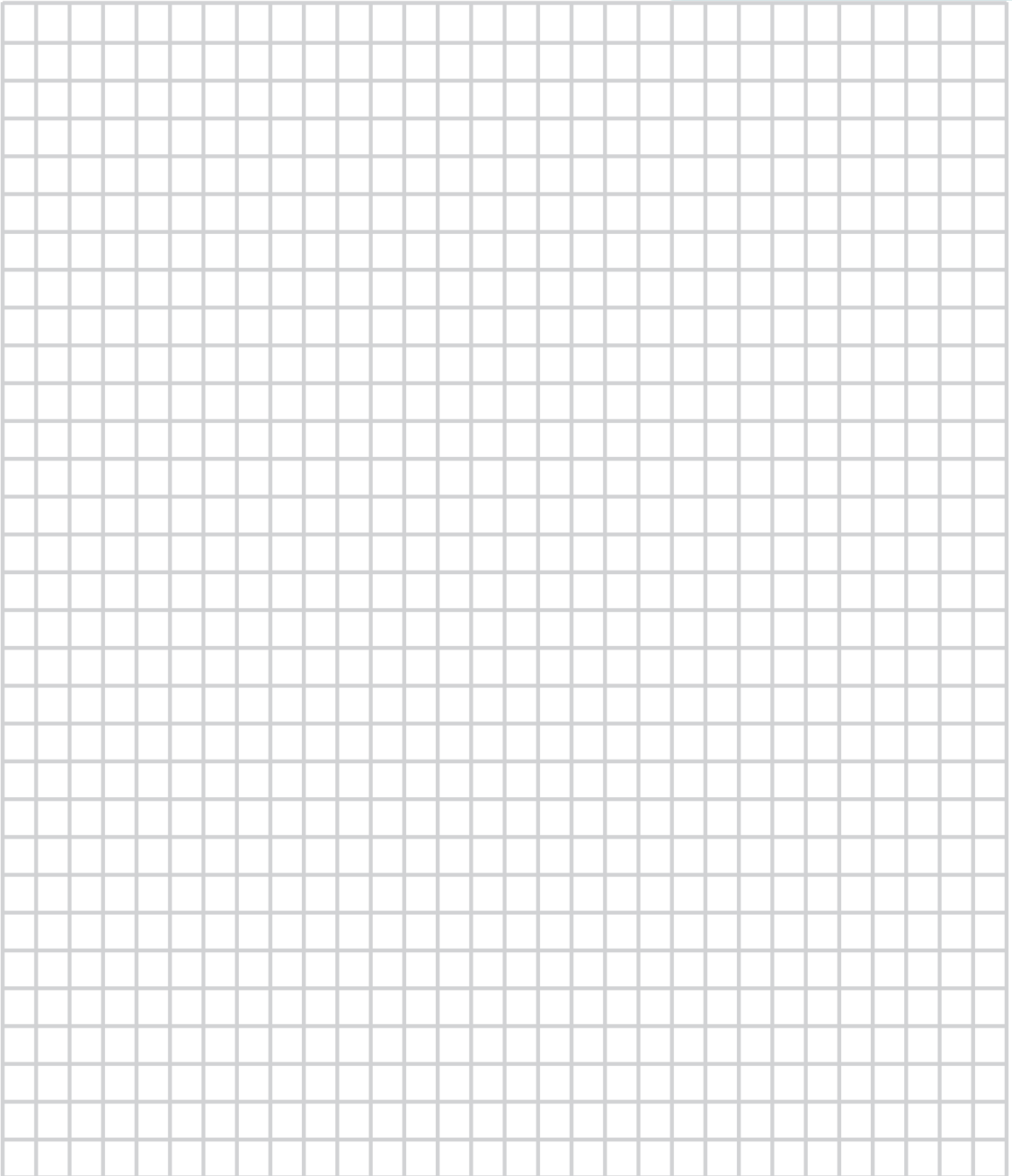

WORK SHEET

Grid Paper for Project Layout

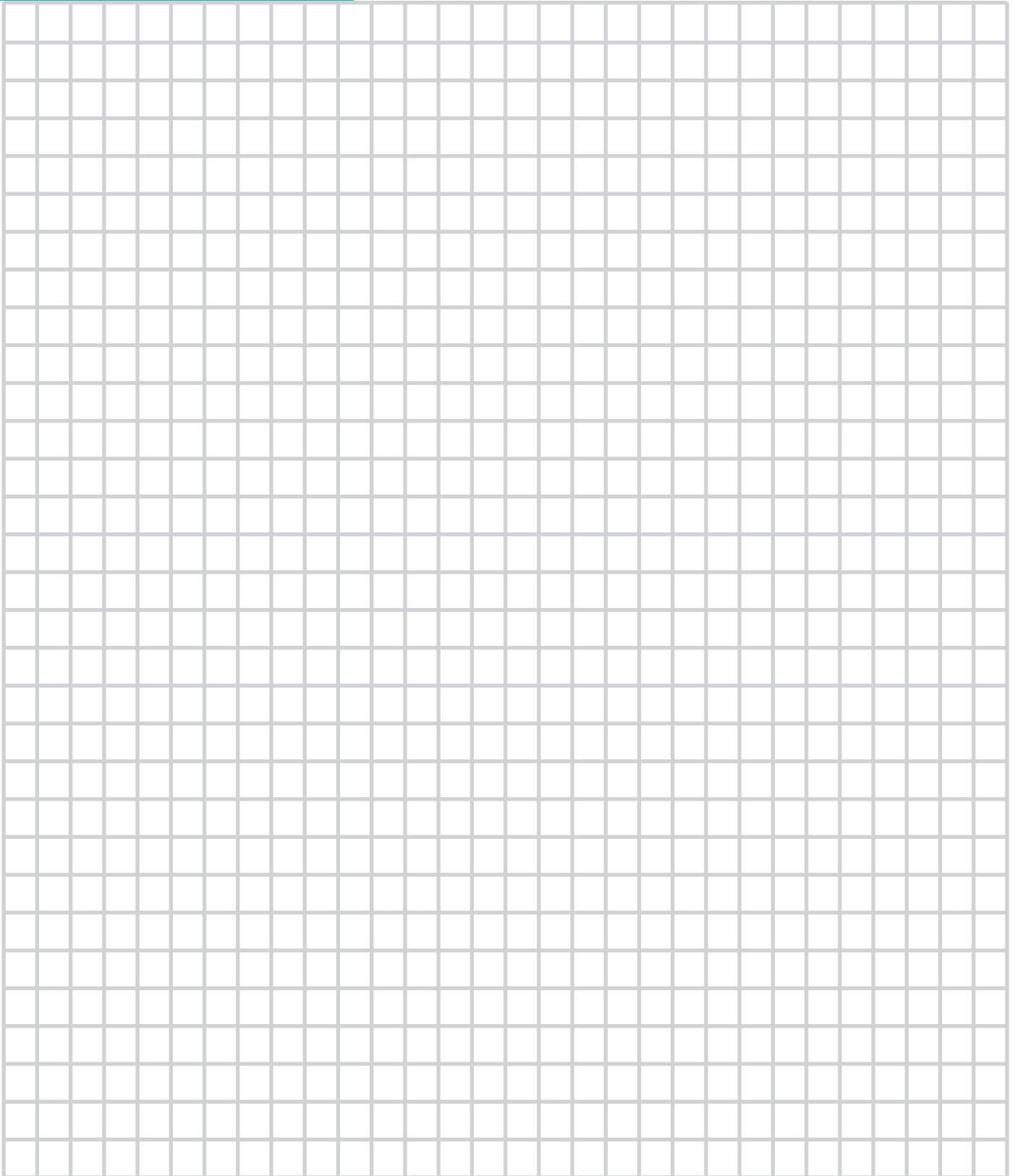

A Do-It-Yourself's Guide to Planning an EP Henry Retaining Wall

If you are planning on building a retaining wall yourself, consider the following questions:



- Is your wall higher than 4 feet?
- Are you building on clay soil or in water conditions?
- Will the wall need to support vehicles?
- Is the wall built on a steep slope or will a slope be created directly behind the wall?
- Are you unable to lift the weight of the units you plan to use?

If you answered "YES" to one or more of these questions, we recommend you hire an EP Henry Authorized Hardscaping Contractor.

Estimating guidelines are intended to be used in conjunction with the EP Henry Idea Catalog and installation guidelines.

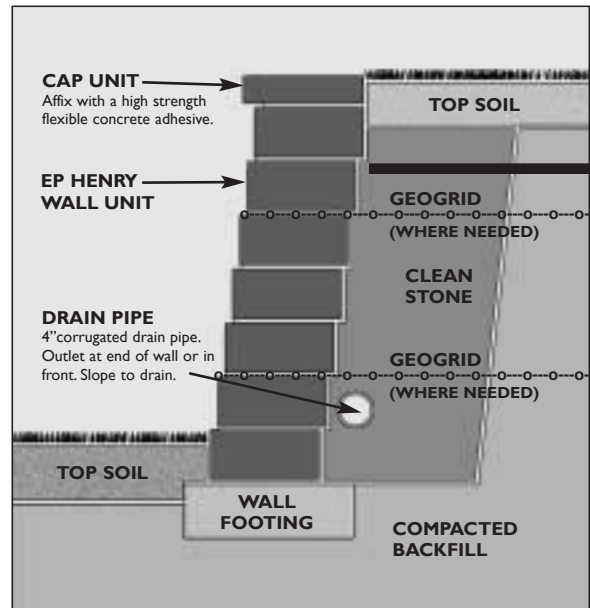

TYPICAL WALL

Product Selection Table

Product	Maximum Wall Height (1)	Minimum Inside Radius (2)	Typical Application
Nursery Stone®	24"	22"	Landscape & garden walls
English Garden Wall	24"	22"	Landscape & garden walls
Coventry® Garden Wall	20"	22"	Landscape & garden walls
Coventry® Wall	36" (unreinforced)	48"	Planter walls, steps, landscaping, small to mid-size retaining walls
Double-sided Coventry® Wall	33"	42"	Free-standing walls, screen & sitting walls, parapet walls, raised patio applications
Terrace Wall™	36"	24"	Planter walls, steps, landscaping, small retaining walls
StoneWall® Select™	40" (unreinforced)	48"	Larger retaining walls
Mesa®	40" (unreinforced)	48"	Larger retaining walls
Vertica®	40" (unreinforced)	69"	Larger retaining walls
Diamond Pro™	40" (unreinforced)	48"	Larger retaining walls

(1) EP Henry recommends consulting a professional engineer for walls over 48". (2) The inside radius changes with wall height.

General Installation Guidelines

Before you begin, call your local utilities company to check your yard for buried electrical lines, cables, etc. This step is essential for your safety, is required by law, and is free in most areas. Also, check with your municipality to see if you'll need a construction permit. "Call Before You Dig" toll free numbers are listed below by state:

Delaware	800-282-8555	New Jersey	800-272-1000	Pennsylvania	800-242-1776
District of Columbia	800-257-7777	New York	800-962-7962	Virginia	800-552-7001
Maryland	800-282-8555				

See your authorized EP Henry Hardscaping Center or our web site www.ephenry.com for installation manual and guidelines, or for the name of an EP Henry Authorized Hardscaping Contractor.

Wall Installation

Estimating Material Needs for Nursery Stone®, English Garden Wall or Coventry® Garden Wall

These products are not intended to be used with geogrid and caps, and are limited to walls no taller than 2.0 feet.

- 1 Select your EP Henry wall type and color.
- 2 Sketch your wall layout to scale. Plan the layout of your proposed wall by measuring the wall length to the nearest foot. Be sure to measure the straight and curved sections of the wall separately.

Example: Entire wall is 8 feet in length and 16" high (4 courses)

- 3 Calculate the length of straight and curved sections of the wall separately.
(A) Total length of straight sections: _____ feet (B) Total length of curved sections: _____ feet
(C) Total lineal feet of wall (A+B): _____ feet

Hint: If your wall will have a lot of curves, lay out the wall location using a garden hose, then measure the straight length of garden hose representing the wall.

- 4 Estimate the number of courses of block in your finished wall. Each course will be 4" high. Remember to include a minimum of one course below grade.

Number of courses of block: _____

Maximum exposed courses is 6 for Nursery Stone and English Garden and 5 for Coventry Garden Wall.

Example: Number of courses of Block is 4

- 5 Calculate the number of straight and tapered pieces you will need by multiplying the total length of the straight and curved sections times the number of courses.

Length of straight sections: ___ ft. x ___ courses = ___ number of rectangular block needed*

Length of curved sections: ___ ft. x ___ courses = ___ number of tapered block needed*

Example: Total length of straight sections: 6 ft. x 4 courses = 24 rectangular block

Total length of curved sections: 2 ft. x 4 courses = 8 tapered block

***Hint:** using a combination of rectangular and tapered units will reduce the size of the V-shaped gaps on the top course of wall.

- 6 Determine the total number of pounds of base/footer material needed by multiplying the number of lineal feet of wall times 50 lbs. This will give you a 4" thick base/footer, 16" wide.

Total lineal feet of wall: _____ x 50 lbs. = _____ total lbs. of base material needed.

Example: 8 ft. x 50 lbs. = 400 lbs. of baselfooter material

- 7 Calculate the amount of clean stone (drainage stone) that you'll need behind the wall. This will give you about 12" of clean stone behind your wall.

Total # of block: _____ x 40 lbs. = _____ total lbs. of clean stone needed behind wall.

Example: 32 blocks x 40 lbs. = 1,600 pounds of clean stone behind wall

- 8 Figure the total cost of your project, follow the EP Henry installation instructions and sit back and enjoy the compliments from your family, friends, and neighbors!

Note: It is recommended that you add 3-5% to material quantities for cuts, waste, etc.

This product is not intended to be used with geogrid, and should be limited to walls no taller than 3.0 feet.

- 1 Select your EP Henry TerraceWall color.
- 2 Sketch your wall layout to scale. Plan the layout of your proposed wall by measuring the wall length to the nearest foot. Estimate the average height based on the block height - 6" (0.5 ft.) increments. Remember to include a minimum of one course below grade.

Hint: If your wall will have a lot of curves, lay out the wall location using a garden hose, then measure the straight length of garden hose representing the wall.

- 3 Calculate the length and height of the wall.

(A) Total linear feet of wall: _____ feet (B) Total average height of wall: _____ feet
(C) Total square feet of wall (A x B): _____ sf

Example: Entire wall is 60 feet in length and 2.5 feet in height which is 150 sf

- 4 Calculate the number of TerraceWall units you will need by multiplying the total square feet of wall by 1.5.

Example: 150 square feet of wall by 1.5 = 225 TerraceWall units

- 5 Calculate the number of corner units needed. Each course will be 6" high (0.5 ft.). Remember to include a minimum of one course below grade.

(A) Number of corners: _____ (B) Average height of corner: _____ feet
(C) Total corner units: $(A \times B) \div 0.5 =$ _____ units

Example: 2 corners at an average height of 2.5 feet = $(2 \times 2.5) \div 0.5 = 10$ corner units

- 6 Calculate the number of 3" rectangular caps you will need by dividing the total length of wall by 1.33.

Example: 60 lineal feet of wall $\div 1.33 = 46$ 3" rectangular cap units



Wall Installation

Estimating Material Needs for TerraceWall™

- 7 Calculate the amount of concrete adhesive needed by adding the number of caps and corner units you will need and dividing the total by 10.

Example: $46 \text{ caps} + 10 \text{ corners} = 56$. $56 \div 10 = 6$ 10-oz. tubes of concrete adhesive

- 8 Determine the total number of pounds of base/footer material needed by multiplying the number of lineal feet of wall times 110 lbs. This will give you a 6" thick base/footer, 24" wide.

Total lineal feet of wall : _____ x 110 lbs = _____ total lbs. of base material needed.

Example: $60 \text{ ft.} \times 110 \text{ lbs.} = 6,600 \text{ lbs of base material}$
 $6,600 \text{ lbs.} \div 2,000 \text{ lbs.} = 3.3 \text{ tons}$

- 9 Calculate the amount of clean stone (drainage stone) that you'll need behind the wall. This will give you about 12" of clean stone behind your wall.

Total square feet of wall : _____ x 0.1 = _____ total tons of clean stone needed behind wall.

Example: $150 \text{ square feet of wall} \times 0.1 = 15 \text{ tons of clean stone behind wall}$

Hint: 1 ton = 2,000 pounds.

- 10 Figure the total cost of your project, follow the EP Henry installation instructions and sit back and enjoy the compliments from your family, friends, and neighbors!

Note: It is recommended that you add 3-5% to material quantities for cuts, waste, etc.



Estimating Material Needs for StoneWall® SELECT™, Mesa®, Vertica® or Diamond Pro™ Retaining Wall

- 1 Select your EP Henry StoneWall SELECT, Mesa, Vertica or Diamond Pro wall color.
- 2 Sketch your wall layout to scale. Plan the layout of your proposed wall by measuring the wall length to the nearest foot. Estimate the average height based on the block height - 8" (0.67 ft.) increments.
Hint: If your wall will have a lot of curves, lay out the wall location using a garden hose, then measure the straight length of garden hose representing the wall.

- 3 Calculate the length and height of the wall.

(A) Total lineal feet of wall: _____ feet (B) Total average height of wall: _____ feet
(C) Total square feet of wall (A x B): _____ sf

Example: Entire wall is 100 feet in length and 3.5 feet in height which is 350 sf

- 4 Calculate the number of StoneWall SELECT or Mesa wall units you will need by multiplying the total square feet of wall by 1.

Example: 350 square feet of wall x 1 = 350 StoneWall SELECT or Mesa units

- 5 Calculate the number of corner units needed. Each course will be 8" high (0.67 ft.). Remember to include a minimum of one course below grade.

(A) Number of corners : _____ (B) Average height of corner: _____ feet
(C) Total corner units: $(A \times B) \div 0.67 =$ _____ units

Example: 2 corners at an average height of 3 feet = $(2 \times 3) \div 0.67 = 9$ corner units

- 6 Calculate the number of 4" high rectangular caps you will need by dividing the total length of wall by 1.48.

Example: 100 lineal feet of wall $\div 1.48 = 68$ 4" rectangular cap units

- 7 Calculate the amount of concrete adhesive needed by adding the number of caps and corner units you will need and dividing the total by 10.

Example: 68 caps + 9 corners = 77 $77 \div 10 = 8$ 10-oz. tubes of concrete adhesive

- 8 Calculate the number of clips/connectors you will need. Vertica and Diamond Pro do not require the use of any clips or pins.

2 clips/connectors are needed for each block except for units on the top course.

(A) Total wall units: _____ (B) Length of wall $\div 1.5$: _____
(C) $(A - B) \times 2$: _____ = # of clips/connectors

Example: 350 wall units minus $(100 \text{ linear feet} \div 1.5) \times 2 = 567$ clips/connectors

- 9 Calculate the amount of geogrid you will need.

If you are installing a retaining wall over 40" (5 courses), you will need to use geogrid soil reinforcement. Other site conditions may warrant the use of geogrid below 40". EP Henry recommends that you consult a professional engineer whenever you utilize geogrid.

Wall Installation

Estimating Material Needs for StoneWall® SELECT™ or Mesa® Retaining Wall

Length of wall x geogrid length x layers of geogrid = Total sf geogrid

Example: 100 x 4 feet of geogrid x 2 layers = 800 sf geogrid

Note: Geogrid is sold by the square yard. 1 sy = 9 sf, so $800 \div 9 = 89$ sy.

- 10 Determine the total number of pounds of base/footer material needed by multiplying the number of lineal feet of wall times 110 lbs. This will give you a 6" thick base/footer, 24" wide.

Total lineal feet of wall : _____ x 110 lbs = _____ total lbs. of base material needed.

Example: 100 ft. x 110 lbs. = 11,000 lbs of base/footer material
 $11,000 \text{ lbs} \div 2,000 \text{ lbs.} = 5.5 \text{ tons of base/footer material}$

- 11 Calculate the amount of clean stone (drainage stone) that you'll need behind the wall by multiplying the number of square feet of wall x 0.1. This will give you about 12" of clean stone behind your wall.

Total square feet of wall : ____ x 0.1 = ____ total tons of clean stone needed behind wall.

Example: 350 square feet of wall x 0.1 = 35 tons of clean stone behind wall

Hint: 1 ton = 2,000 pounds.

- 12 Figure the total cost of your project, follow the EP Henry installation instructions and sit back and enjoy the compliments from your family, friends, and neighbors!

Note: It is recommended that you add 3-5% to material quantities for cuts, waste, etc.



StoneWall SELECT Wall



Mesa Wall

Estimating Material Needs for Coventry® Wall

1 Select your EP Henry Coventry Wall color.

2 Sketch your wall layout to scale.

Plan the layout of your proposed wall by measuring the wall length to the nearest foot. Estimate the average height based on 6" (0.5 ft.) increments, as Coventry Wall units come in 3" and 6" heights. Remember to include a minimum of one 6" course below grade.

Hint: If your wall will have a lot of curves, lay out the wall location using a garden hose, then measure the straight length of garden hose representing the wall.

3 Calculate the length and height of the wall.

(A) Total linear feet of wall: _____ feet (B) Total average height of wall: _____ feet
(C) Total square feet of wall (A x B): _____ sf

Example: Entire wall is 100 feet in length and 2 feet in height which is 200 sf

4 Calculate the amount of Coventry Wall units you will need.

Coventry Wall is calculated by the square foot. Both the 3" high units and 6" high units come in five different lengths in cubes of 50 square feet. You can use 100% of either 3" or 6" high units or a combination of the two. Speak to your EP Henry Hardscaping Center for recommended percentages when using both heights.

*Coventry Wall may be sold by the pallet, layer or square foot.

Example: 200 square feet of wall in a combination of 70% 3" units and 30% 6" units
200 sf x 70% = 140 sf 3" units 200 sf x 30% = 60 sf 6" units

5 Calculate the amount of corner units needed.

(A) Number of 90° corners in wall : _____

(B) Wall height: _____

(C) Average number of corner units per foot of wall height (select one from below): _____

1. All 6" high corner units: 2 per foot of wall height

2. All 3" high corner units: 4 per foot of wall height

3. Combination 3" & 6" corner units: 3 per foot of wall height

(D) A x B x C = _____ total number of corners needed. If using a combination, a typical ratio would be 2:1 3" to 6" units.

Example assuming 4 corners and a 2' high combination wall:

4 x 2 x 3 = 24 total number of corners needed. 3" corners = 24 x 66% = 16

6" corners = 24 x 33% = 8 for a 2:1 ratio

6 Calculate the number of 3" universal Coventry caps you will need by dividing the total length of wall by 1.25.

Example: 100 lineal feet of wall ÷ 1.25 = 80 3" universal Coventry cap units

7 Calculate the amount of concrete adhesive needed by adding the number of caps and corner units you will need and dividing the total by 10.

Example: 80 caps + 8 corner units = 88 88 ÷ 10 = 9 10-oz. tubes of concrete adhesive

Wall Installation

Estimating Material Needs for Coventry® GardenWall

- 8 Calculate the number of pins you will need.

1 pin needed per lineal foot for each course except top course.

- (A) Average # of courses = (wall height \div 0.5) \times 1.5 (assumes half 3" & half 6"): _____ - 1 = _____
(B) Length of wall: _____
(C) (A \times B) = _____ # pins

Example: 2 ft. wall height (2 \div 0.5) \times 1.5 = 6 - 1 (top course) = 5 \times 100 lineal ft. = 500 pins

- 9 Determine the total number of pounds of base/footer material needed by multiplying the number of lineal feet of wall times 75 lbs. This will give you a 6" thick base/footer, 16" wide.

Total lineal feet of wall: _____ \times 75 lbs = _____ total lbs of base/footer material needed.

**Example: 100 ft. \times 75 lbs. = 7,500 lbs. of material
7,500 lbs. of base - footer material \div 2,000 lbs. = 3.75 tons**

- 10 Calculate the amount of clean stone (drainage stone) that you'll need behind the wall by multiplying the number of square feet by 0.1. This will give you about 12" of clean stone behind your wall.

Total square feet of wall: _____ \times 0.1 = _____ total tons of clean stone needed behind wall.

Example: 200 square feet of wall \times 0.1 = 20 tons of clean stone behind wall

Hint: 1 ton = 2,000 pounds.

- 11 Figure the total cost of your project, follow the EP Henry installation instructions and sit back and enjoy the compliments from your family, friends, and neighbors!

Note: It is recommended that you add 3-5% to material quantities for cuts, waste, etc.



Estimating Material Needs for Doubled Sided Coventry® Wall

1 Select your EP Henry Double Sided Coventry Wall color.

2 Sketch your wall layout to scale.

Plan the layout of your proposed wall by measuring the wall length to the nearest foot. Be sure to measure the straight and curved sections of the wall separately.

Example: Entire wall is 100 feet in length and 2 feet in height

3 Calculate the length of straight (rectangular units) and curved (radius units) sections of the wall separately.

(A) Total length of straight sections: _____ feet

(B) Total length of curved sections: _____ feet

(C) Total lineal feet of wall (A+B): _____ feet

Hint: If your wall will have a lot of curves, lay out the wall location using a garden hose, then measure the straight length of garden hose representing the wall.

4 Calculate the square footage of the Double Sided Coventry Wall.

Double Sided Coventry Wall is calculated by the square foot in radius or straight units. Both the 3" high units and 6" high units come in five different lengths in cubes of 50 square feet.

(A) Total lineal feet of straight units: _____ feet x _____ average height = _____ sf

(B) Total lineal feet of radius units: _____ feet x _____ average height = _____ sf

(C) Total square feet of wall (A + B): _____ sf

* Double Sided Coventry may be sold by the pallet, layer or square foot.

5 Calculate the amount of corner units needed.

(A) Number of 90° corners in wall: _____

(B) Wall height: _____

(C) Average number of corner units per foot of wall height (select one from below): _____

1. All 6" high corner units: 2 per foot of wall height

2. All 3" high corner units: 4 per foot of wall height

3. Combination 3" & 6" corner units: 3 per foot of wall height

(D) $A \times B \times C =$ _____ total number of corners needed. If using a combination, a typical ratio would be 2:1 3" to 6" units.

Example assuming 4 corners and a 2' high combination wall:

$4 \times 2 \times 3 = \underline{24}$ total number of corners needed. $3''$ corners = $24 \times 66\% = 16$

$6''$ corners = $24 \times 33\% = 8$ for a 2:1 ratio

6 Calculate the number of 3" universal Coventry caps you will need by dividing the total length of wall by 1.25.

Example: 100 linear feet of wall \div 1.25 = 80 3" universal Coventry cap units

Wall Installation

Estimating Material Needs for Doubled-Sided Coventry® Wall

- 6 Calculate the amount of concrete adhesive needed by adding the number of caps and square feet of corner units you will need and dividing the total by 10.

Example: $80 \text{ caps} + 8 \text{ corner units} = 88$ $88 \div 10 = 10$ 10-oz. tubes of concrete adhesive

- 7 Calculate the number of pins you will need.

1 pin needed per lineal foot for each course except top course.

(A) Average # of courses = (wall height \div 0.5) \times 1.5 (assumes half 3" & half 6"): _____ - 1 = _____

(B) Length of wall: _____

(C) (A \times B) = _____ # pins

Example: 2 ft. wall height $(2 \div 0.5) \times 1.5 = 6 - 1$ (top course) = 5 \times 100 lineal ft. = 500 pins

- 9 Determine the total number of pounds of base/footer material needed by multiplying the number of lineal feet of wall times 110 lbs. This will give you a 6" thick base/footer, 24" wide.

Total lineal feet of wall : _____ \times 110 lbs = _____ total lbs. of base material needed.

Example: Total length of wall: 100 ft. \times 110 lbs. = 11,000 lbs of baselfooter material
 $11,000 \text{ lb.} \div 2,000 \text{ lbs.} = 5.5 \text{ tons}$

- 10 Calculate the amount of clean stone (drainage stone) that you'll need behind the wall by multiplying the number of square feet by 0.1. This will give you about 12" of clean stone behind your wall.

Total square feet of wall : _____ \times 0.1 = _____ total tons of clean stone needed behind wall.

Example: 200 square feet of wall \times 0.1 = 20 tons of clean stone behind wall

Hint: 1 ton = 2,000 pounds.

- 11 Figure the total cost of your project, follow the EP Henry installation instructions and sit back and enjoy the compliments from your family, friends, and neighbors!

Note: It is recommended that you add 3-5% to material quantities for cuts, waste, etc.

Please refer to the appropriate step on the guide pages for the EP Henry Wall System you have selected.

Product	Calculation	Unit	Price	Extended
Wall units needed (all systems except Coventry Wall & Double Sided Coventry Wall)		Piece		
Wall units needed (Coventry Wall & Double Sided Coventry Wall)		SF		
Corner units		Piece		
Cap units		Piece		
Adhesive		Tube		
Pins or clips		Piece		
Geogrid		SY		
Footer stone (tons)		Ton		
Drainage stone (tons)				
Total Material Cost				
Tool rental				
Delivery				
Miscellaneous				
Tax				
Project Total				

Don't forget our special financing through Commerce Bank to help pay for your project!

Tool Checklist for Walls



- Shovel
- Steel rake
- Push broom
- Hand tamper
- Wheelbarrow
- Garden hose
- Tape measure
- Level
- Stringline
- Chalkline
- Trowel
- Screed rails
- Screed board
- Marking utensil
- Gloves
- Dust mask
- Eye protection
- Ear protection
- Vibratory plate compactor
- Table saw with diamond tip blade

Do-It-Yourself

Contest Entry Form

Proud of your EP Henry Do-It-Yourself Project?

Enter your project in our "Do-It-Yourself Photo Contest" for a chance to win prizes and be featured in EP Henry's Idea Catalog, website and other marketing items.

Don't just "sit back and enjoy the compliments from your family, friends and neighbors" once you've completed your EP Henry Hardscaping DIY project ... submit it to us for a chance to show the "world" how good you are and for a chance to win a cash prize!

It's simple. Just fill out the following form and send it to us with at least two each "before" and "after" photos. Here are the guidelines:

- 1 All entries must be received by November 30, 2005.
- 2 At least four photos must be included in each submission - two showing the area before the start of the project and two showing the same area after the project is complete. For best results, try to use the same angle(s) for the before & after shots.
- 3 "After" shots must be completed with Hardscaping and preferably landscaped.
- 4 Cash awards will be as follows:
 - First Place \$1,000
 - Second Place \$ 500
 - Third Place \$ 250
- 5 High resolution photos are preferred.
- 6 All photos become the property of EP Henry.
- 7 The person submitting the photos certifies that he/she is the property owner and authorizes EP Henry to use them for any and all EP Henry marketing purposes.
- 8 Send your entries to Marketing Coordinator, EP Henry, P.O. Box 615, 201 Park Avenue, Woodbury, NJ 08096.

CONTEST ENTRY AND PHOTOGRAPHY RELEASE FORM

I consent to the use of photograph(s) of my property by EP Henry Corporation for promotional and advertising purposes. I waive all rights and fees for EP Henry Corporation to use said photo(s) for ads, brochures, website or any other promotional use. I also understand that there is no limitation in terms of time for EP Henry to use photo(s). This agreement extends to photographs of buildings, property and people as applicable. It is agreed by EP Henry that neither the owner's name nor address will be disclosed in connection with any promotional and advertising purposes unless expressly consented to by the owner.

Name: _____ Phone: _____

Address: _____

City, State, Zip: _____

Signature: _____

Do-It-Yourself Photo Gallery



BEFORE



AFTER

While much of our product is installed by independent EP Henry Hardscaping contractors, many people choose to do-it-themselves. EP Henry Hardscaping Centers hold regularly scheduled seminars for those who choose that path. We're proud to showcase the winners and some runners-up of our first "Do-It-Yourself" Photo Contest.



This beautiful raised patio incorporating Symetry® Pavers and Mesa® Wall took First Place Winner in the 2004 EP Henry "Do-It-Yourself" Photo Contest.



AFTER



BEFORE



AFTER



The Second Place Winner included a walkway and patio (partially under their deck) of Colonial Stone with Coventry Walls and steps.

Do-It-Yourself

Photo Gallery

Whether you want to build a dramatic entrance leading to your front door or create a quiet back yard get-away, EP Henry Hardscaping Products provide a beautiful accent to your home landscape that you can enjoy for years to come.

You can also be proud that you did-it-yourself!



Tied for Third Place in the 2004 EP Henry "Do-It-Yourself" Photo Contest are this raised patio (above) and curving walkway, steps and walls (right).



An "Honorable Mention" goes to this cozy backyard patio.

Do-It-Yourself Photo Gallery



More "Honorable Mentions".



DAY



EP HENRY
Hardscaping™ For All Walks of Life®

201 PARK AVENUE • PO BOX 615 • WOODBURY, NJ 08096 • 1 800 44 HENRY • 856 845 6200 • www.ephenry.com • e-mail: info@ephenry.com

© EP HENRY 2005 ALL RIGHTS RESERVED. REPRODUCTION OF ANY PART OF THE CONTENTS OF THIS CATALOG IS PROHIBITED.